

**INSTRUCTION  
BOOK  
for  
FT-DX100/150 TRANSCEIVER**

# INSTRUCTION BOOK

for

## FT-DX100/150 TRANSCEIVER

The model FT-100/150 SSB Transceiver is a precision built, compact, high performance transceiver providing SSB (USB and LSB selectable), CW and AM modes of operation. This transceiver operates at an input of 120 watts PEP for SSB and CW, 50 watts for AM, on all bands, 80 through 10 meters. All circuits, except the final and driver stages, are transistorized.

The FT-100/150 is self-contained in that it requires only a microphone, a speaker and an antenna for operation either fixed or mobile. The FT-100/150 is designed for 100/110/200 or 220 volts AC, 50/60 cps operation, or for 12 volts DC mobile operation after installation of the DC to DC convertor. The selection of AC or DC sources is made automatically with the proper line cord supplied. For efficient mobile operation, a separate switch is provided to turn off the tube filaments. This feature significantly reduces the drain on the battery during stand-by periods.

A specially designed high frequency crystal lattice filter is utilized for sideband generation. Receiver frequency adjustment (RFA) is provided to shift the receiver frequency approximately 5 kc either side of the transmitting frequency. The RFA may be adjusted such that it will lock the receiver frequency to the transmitting frequency. In addition, provisions have been made for the use of an external VFO unit. A switch on the front panel selects the transmitter to an external VFO control mode. This feature provides the operator with independent transmitting and receiving frequencies. Moreover, this switch also selects any built-in crystal oscillator circuit for crystal control operation.

Other features include a built-in VOX (voice control) circuit) and crystal controlled 100Kc calibrator, and provisions have been made for using an external linear amplifier, such as our FL 2000.

Three auxiliary bands are provided for the use in of amateur band

# SPECIFICATIONS

Type of emission:	USB or LSB (selectable) CW/AM.
Frequency range:	3.5-4.0Mc, 7.0-7.5Mc, 14.0-14.5Mc, 21.0-21.5Mc, 27.9-28.5Mc, 28.5-29.0Mc, 28.9-29.5Mc,
Power input:	SSB CW 120 watts PEP (slightly lower on 10 meter), AM 50 watts.
Carrier suppression:	40 db.
Sideband suppression:	40 db.
Distortion products:	better than 25 db.
Spurious response:	Down at least 40 db.
Antenna output impedance:	40 to 100 ohms unbalanced.
Sensitivity:	Less than 1 uv for 10 db. S/S+N ratio.
Selectivity:	2.3Kc at 6 db., 4.5Kc at 55 db., for both transmit and receive.
Audio output:	1 watt at 10% distortion.
Power requirement:	AC: R 35 watts, T 150 watts. DC: STBY 1.1 A, R 2.5A, T 13A.
Dimensions:	153m m high, 334m/m wide, 262m/m deep.
Weight:	Approximately 30 lbs.

## CIRCUIT DESCRIPTION

### TRANSMIT FUNCTION:

When the push-to-talk switch on the microphone is pressed or operation switch is placed at OPER position, the transmitter portion of the transceiver is activated and it generates the transmitting signal in the following manner:

Carrier is generated by two transistors, 2SC372's, one of which generates 3,179.4Kc for USB, AM and CW; the other generates 3,181.4Kc for LSB, and is applied to the ring balance modulator. The carrier oscillator circuit is selected, by the mode switch on the front panel, for proper frequency and cut off for AM reception. The audio signal from the microphone is amplified through 2SB54 and 2SB94 and applied to the ring balance modulator. Carrier balance is obtained by a potentiometer and trimmer capacitor on the chassis. The double sideband suppressed carrier signal, from the ring balance modulator, is then passed through the crystal lattice filter which suppresses the unwanted sideband.

The SSB signal from the filter is next amplified through the 3,180Kc IF amplifier stage. The proper amount of carrier, for CW or AM operation, is inserted into the circuit by unbalancing the ring modulator through the mode switch. For CW operation, carrier frequency is shifted approximately 800cps into pass band of crystal filter. The 3,180Kc signal output from T204 is then applied to the VFO mixer. The VFO signal, which is tunable from 8,400Kc to 8,900Kc, is also injected into this VFO mixer. This injection voltage is generated by TR402 (2SC372). A tunable IF transformer, T301, connected to the output of the VFO mixer, tunes the frequency range 5,220Kc to 5,720Kc.

This IF frequency is the result of subtractively mixing the incoming 3,180Kc signal with the VFO signal. The transformer T301 is gang-tuned with the VFO and thus is always accurately tuned to the frequency to eliminate spurious signals.

The 5,720 to 5,220Kc signal from the VFO mixer is applied to the high frequency mixer, TR104 (2SA246). An injection from the heterodyne crystal oscillator, TR102 (2SC372), is also applied, thus producing the transmitting frequency. The crystal frequency will be 9,220, 12,720, 19,720, 26,720 or 34,220Kc, depending upon the position of the bandswitch, and subtractively mixes with the incoming signal to obtain the final transmitting frequency. The output from the heterodyne mixer, which appears across coil L101 or L105, is applied to the grid circuit of driver tube V1 (12BY7A) through a trap coil L106 which tunes to 5,600Kc. The output from the driver stage is next coupled to the grid circuit of the final linear amplifier tubes (6JM6's). The output coils of the driver stage and the heterodyne mixer are gang-tuned by a preselector capacitor on the front panel.

Neutralization of the final linear amplifier is accomplished by feeding back a small amount of the output through TC601 to the bottom of the plate coil on the driver tube. Output power from the final amplifier tube is then fed to a pi network which is designed to match a 40 to 100 ohm load. When the antenna relay is closed, the output circuit of the pi network is connected to the antenna feed line. The amplified automatic level control (ALC) circuitry operates in the following manner: When flattopping occurs in the final amplifier, an audio signal which is proportional to the amount of flattopping, appears in the bias circuit. This signal is coupled to the ALC amplifier transistor (2SB54) TR401 whose output is subsequently rectified by SH-1 diodes. The resulting DC voltage is applied to the DC amplifier, TR204 2SD 191, thus producing an output DC voltage which is in direct proportion to the amount of flattopping in the final amplifier grid circuit. This DC voltage in turn controls the gain of the 3,180Kc amplifier chain.

## RECEIVE FUNCTION :

With the microphone push-to-talk switch released when operation switch is at PTT position, a signal from the antenna is coupled to the antenna coils, through the antenna relay and a trap coil, L608, tuned to 5,600Kc. D106 and D107, across the antenna coil, conduct only when extremely strong signals are present and do not otherwise affect the circuit. The signal tuned at the antenna coil is coupled to the base circuit of TR-101 (2SA239), the RF amplifier. The amplified signal, from TR101, is then applied to the heterodyne mixer TR103 (2SA246) and produces a 5,720 to 5,220Kc signal with an injection from the crystal oscillator TR102. The 5,720 to 5,220Kc signal is then mixed, by the VFO mixer TR302 (2SA93), to produce a 3,180 Kc IF signal with injection from the VFO. The 3,180 Kc signal is applied to 3,180 Kc crystal lattice filter and next amplified through a 3 stage IF amplifier chain. The amplified signal is then coupled through T205 to the ring demodulator for SSB and CW detection. The carrier injection to the ring demodulator produces an audio output which is then applied to audio amplifier TR208 (2SB54) through the mode switch. AM detection is accomplished by coupling the received signal to a separate diode detector D201 (1S-1007), from T205. The amplified audio signal is coupled to the audio driver, TR304 (2SB94), through the audio gain control potentiometer on the front panel. The audio signal is then amplified to speaker level by a class B amplifier, TR305 and TR306 (2SB200's). The 3,180Kc IF signal from the final amplifier stage is applied to the AM detector AGC diode D201 (1S-1007) which rectifies the incoming signal. The resulting DC voltage is applied to the AGC/ALC amplifier, TR204 (2SD191), whose output DC voltage is supplied to the 3,180Kc IF amplifier stage and the RF amplifier Stage, thus controlling the gain of the receiver. This control voltage is also amplified by the S-meter amplifier, TR205 (2SD191), to obtain the proper level for S-meter readings. The meter is switched by a relay to show final stage IC current or relative power output during transmit. Receiver frequency adjustment (RFA) is used to permit a slight frequency adjustment, or offset, in the receiver with respect to the transmitting frequency. This control may be turned to the OFF position when the receiving frequency is exactly the same as the transmitting frequency. The adjustment resistor is factory set so that the VFO frequency, on receive, is actually the same as on transmit at center position of RFA potentiometer. A varicap diode, connected in series with a small capacitor to the hot end of the VFO coil, works to shift the VFO frequency using the voltage applied through the potentiometer. The amount of shift is adjusted by a potentiometer from the front panel which applies a DC voltage to the diode. When transmitting, place the potentiometer control to the center position (approximate) of the scale. This will provide the diode with the proper voltage to place the receive frequency on the transmit frequency. The voice control is built-in and circuited by a switch on the rear panel.

## POWER SUPPLY :

The FT-100/150 contains a power supply for 100/110 /117/200/220, or 234 volts, 50 or 60 cps AC operation. A provision is made for easy installation of a DC-12 volt DC to DC convertor supplied with the unit. After building the DC-DC convertor circuit, in the power supply compartment, the necessary connections are made automatically to operate the supply in either mode (AC or DC) by inserting the proper power cord into the receptacle on the rear panel.

## INSTALLATION

It is recommended that an excessively warm location be avoided. The transceiver should be placed in a location that provides adequate space around it thus permitting free air circulation through the cabinet openings. For fixed operation from an AC supply, use the AC cord to the receptacle at the rear. The chassis grounding connection that is provided on the rear of the transceiver should be connected to an actual ground by a heavy lead.

It is not recommended to use gas or electrical conduit pipes. The grounding lead should be kept as short as possible. performance both in receiving and transmitting will depend largely on the antenna. Antenna impedance of this transceiver has been designed to match a 50 to 100 ohm resistive load. Any antenna designed for use on the amateur bands may be used. If the impedance of transmission line or antenna is far from this value, a suitable antenna tuner must be used between the transceiver and antenna system.

The FT-100/150 transceiver may be operated in conjunction with any conventional linear amplifier. A plug on the rear panel provides relay contacts for the external linear amplifier.

After installing the DC to DC convertor, placing it in the power supply compartment using the parts supplied, the FT 100 150 will operate from any 12 volts negative ground battery supply. Connect the DC power cord supplied to the rear panel receptacle. When making connections to the car battery, be sure to connect the red lead to the positive (+) terminal and the black lead to the negative (-) terminal. Reversed connections could permanently damage the transistors and diodes used in the FT-100/150. A 15 ampere fuse must be used between the transceiver and the battery supply.

Check the car voltage regulator and make certain that, during charging, the voltage does not exceed 14.6 volts. This must be done prior to mobile operation of the FT-100/150 since excessively high voltage can permanently damage solid state devices.

On the higher frequency bands, the noise generated by the ignition system or generator will cause poor reception of weak signals. Noise reduction information given in amateur literatures will be helpful.

## IMPORTANT

Do not operate the FT-100/150 transceiver before completely familiarizing yourself with this instruction book. Improper adjustment of the controls may result in signals of poor quality.

## PRINCIPLES OF OPERATION

### POWER:

The power ON/OFF switch is located at the left, on the front panel. Pressing the upper side of the switch turns the unit on. Since the receiver portion is entirely transistorized, no warm-up period is required.

### PTT/OPER:

The operation switch is located at the right side of the power switch, on the front panel.

### TUNING DIAL:

The large knob, at center of the front panel, controls the operating frequency. This dial actually consists of two dials, the main dial in the dial window and a 50 division subdial on the knob. The main dial has two calibrated scales which are colored red and black to match the color of the band switch. The scales are 10Kc per division. The subdial, on the tuning knob, is divided in 50 divisions, where 1 division is approximately equal to 1Kc. The subdial may be adjusted holding knob firmly for calibration.

## MIC/AM CARRIER

A concentric shaft potentiometer is used to control the MIC gain and the carrier level of AM for transmitting. The large knob controls AM carrier potentiometer and the small knob controls the MIC gain.

The microphone jack has three poles, i.e., microphone input, push-to-talk and ground connection. Refer to the illustration in the back of this manual for mic plug connections.

## MODE:

This switch is used to select the desired mode of operation. Sideband is selected by removing the DC voltage from the one of carrier oscillators. On the CW position, the USB oscillator is used and carrier is shifted approximately 800 cps higher however, the microphone amplifier is inoperative. The ring modulator is unbalanced to insert carrier into the circuit. On the AM position, the USB oscillator is operational during transmit only, and carrier is inserted in the same manner as described above. A separate detector for AM and SSB, CW is also selected by this mode switch.

## AF/RF GAIN:

A concentric shaft potentiometer is used to control the RF and AF gain of the receiver. The large knob controls the RF gain potentiometer, and the small knob controls the audio gain potentiometer.

## BAND:

This control is used to select the amateur band desired.

BAND	FREQUENCY RANGE
80	3,500 to 4,000 Kc.
40	7,000 to 7,500 Kc.
20	14,000 to 14,500 Kc.
15	21,000 to 21,500 Kc.
10A	28,000 to 28,500 Kc.
10B	28,500 to 29,000 Kc.
10C	29,000 to 29,500 Kc.



## RFA:

This knob is used to shift the receiving frequency approximately 5 Kc either side of the transmitting frequency; thus, it is possible to set the receiver to a convenient listening point without affecting the transmitting frequency. At the OFF position, your transmitting frequency is exactly the receiving frequency.

## SELECT:

This switch selects the VFO injection. At the INT position, the main tuning knob is used to control the operating frequency for both transmit and receive. At the EXT 1 position, an external VFO can be used for transmitting only; thus, providing independent transmitting and receiving frequencies. At the EXT 2 position, an external VFO can be used for both transmit and receive. This feature provides remote VFO control in mobile installation. At the CH 1 to 3 positions, a crystal oscillator circuit is connected instead of the VFO.

This feature provides the operator with three pretuned channels anywhere within the amateur bands. This capability is particularly valuable for those scheduled contacts. The relation between the VFO frequency and operating frequency is as follows:

VFO DIAL	0	100	200	300	400	500
KC	500	600	700	800	900	0

## OSCILLATING FREQUENCY

KC	8.900	8.800	8.700	8.600	8.500	8.400
----	-------	-------	-------	-------	-------	-------

## CALIB:

This switch controls the built in 100 Kc crystal calibrator. Pressing the switch up, to the ON position, inserts a beat signal every 100 Kc on all bands, and an antenna relay is activated to cut the antenna from the circuit to provide accurate calibration.

## METER SWITCH:

The meter is selected to measure the total current of the cathode final tubes at IC position and relative power output at PO position. For receiving, the meter converts automatically to an S meter.

## HEATER:

This switch turns off the transmitter tube heaters thus saving battery drain during long periods of listening. Pressing the switch up to the ON position, supplies heater voltage. After a 30 second warm-up period, the transmitter is ready to transmit.

## PA TUNE & LOADING:

These controls are used to tune the final pi output network. The approximate setting of PA tune is indicated on the panel.

## PRESELECTOR:

This control is used to tune the front end for receiving and the driver stage for transmitting.

## TRANSMITTER TUNEUP:

Turn on the power switch and allow 30 seconds for warm-up of the transmitter tubes. Set the band switch to the desired band. Tune the preselector for maximum receiver noise. Set the mode switch to AM mode and operation switch to OPER position or press the push-to-talk switch on the microphone at operation switch at PTT position. Tune the preselector for maximum IC reading. Tune the PA TUNE for a sharp dip in meter indication. At this point, set the meter switch to OP position and tune the LOAD control for maximum meter reading. Repeat alternating adjustments of the PA TUNE and LOAD controls until the meter reads maximum output. For AM operation, adjust the AM CAR potentiometer until the tuned plate current IC shows 100 milliamperes. Advance the MIC GAIN potentiometer until IC kicks 5-10 mA up with normal speaking into microphone. For SSB operation, set the mode switch to either USB or LSB position and press the PTT switch. The idle current at IC position is approximately 30 mA. Speaking into microphone normally, IC kicks up to approximately 100 mA. It is very important to set the mic gain at the proper position. If it is too high, excessive distortion and splatter will be produced. On the other hand, if the setting is too low, it will result in reduced transmitter output.

For CW operation, set the mode switch to CW position and plug the key into jack on rear panel and press the key down. Press operation switch to OPER position. Tune as above quickly. Key down IC is approximately 100mA.

For VOX operation, set a switch on the rear panel to VOX position and advance a VOX sensitivity potentiometer in normally speaking into the microphone until the voice activate the transceiver to transmit. Excessive setting of the potentiometer may cause unstable operation. Advance the Antitrip potentiometer to prevent the receiver output activates the transceiver.

# ALIGNMENT

Do not attempt to align this transceiver until completely familiarized to the instruction book.

## DANGER

High voltage is present in the equipment whenever the transceiver is turned on. High voltage also remains in the filter capacitors after the unit is turned off; therefore, make sure there is no high voltage in the circuit before making internal adjustments.

Low transmitter output generally indicates weak tubes. If the off-resonance plate current of the final tube at maximum drive becomes less than 200 ma. as indicated on the front panel meter (meter switch IC position), either the driver or final tubes may require replacement.

The receiver portion of this transceiver is fully transistorized; therefore, the sensitivity should not diminish age with except for a slight drift in the tuning circuit. In this case, the RF trimmer and slugs may require adjustment.

## CHASSIS REMOVAL FROM THE CABINET:

Remove the six screws on the cabinet and two screws on the bottom and carefully slide the chassis and panel assembly out the front of the cabinet.

## TEST EQUIPMENT REQUIRED:

Recommended service equipment for alignment or trouble shooting is:

- A. Sensitive VTVM with an RF probe.
- B. Signal generator covering 3 to 35 mc
- C. Calibrated communication receiver
- D. Oscilloscope
- E. Audio oscillator.
- F. Dummy load.

## **NOTE:**

Care must be taken to avoid accidental short circuits which can cause permanent damage to the transistors.

## **CARRIER BALANCE:**

Connect the VTVM RF probe to the center arm of the carrier balance potentiometer. A reading of at least 1 volt RMS indicates correct performance of the carrier oscillator circuit.

Tune up the transceiver on any band in SSB mode. Connect the VTVM, using an RF probe, to the antenna terminal. Adjust the carrier balance potentiometer and trimmer capacitor, on the chassis, alternately for minimum indication on the VTVM. Repeat this procedure for both USB and LSB. Some compromise for both sidebands may be necessary since there may be a slight difference in carrier balance between the two modes.

## **NOTE:**

Carrier frequency adjustment in the carrier oscillator compartment can also affect carrier balance; however, care must be taken to place the carrier on the notch of the filter.

## **VFO:**

Faulty VFO operation is indicated when no receiver operation is obtained on any of the bands selected. A reading of approximately 0.2 to 0.3 volt is normally obtained with a VTVM connected to the output coaxial cable in the VFO box. Adjust the VFO buffer coil (L401) for a peak at the center of the VFO frequency scale. To adjust the VFO frequency, set the RFA control to OFF, tune the transceiver to a beat signal of the built-in 100 Kc calibrator and, adjust the VFO trimmer (TC401) until the signal is zero beat at the correct dial reading.

## **HETERODYNE OSCILLATOR:**

Connect a VTVM to the output coaxial cable from the oscillator section. Set the band switch to 10 meters. Adjust L122 for a maximum VTVM reading. A reading of approximately 0.2 volt indicates normal operation of the oscillator. Next, set the band switch to 15 meters and adjust the appropriate ceramic trimmer for a reading of 0.2 volt. In this manner, adjust all remaining trimmers (TC101-TC104) on each respective band for 20, 40 and 80 meters.

## **T201:**

Connect a dummy load to the antenna terminal and tune up the transmitter on 3.8 Mc. Connect a two-tone signal generator into the microphone jack and, with the microphone button pressed or operation switch at OPER position, tune the transmitter controls for maximum power output. Next, reduce the input of the two-tone signal to avoid saturation and adjust T201 for maximum output.

### **T203 and T204:**

With the condition described above, adjust the slugs of both transformers for maximum output.

### **T301:**

Set the VFO to the 0 position and adjust the slugs of T301 for maximum output. Set the VFO to the 500Kc position and adjust TC 402 and TC-403 for maximum output. Repeat this procedure until tracking is accomplished.

### **T205:**

Tune the receiver to an incoming signal or use the 100Kc calibrator signal and adjust the slug for maximum S-meter reading. Adjust the RF gain control for proper reading of S-meter to avoid saturation.

### **HETERODYNE MIXER & DRIVER:**

Set the transceiver to transmit on 28.75Mc. in the AM mode, and adjust the transmitter controls for maximum output. Set the preselector control knob to center scale and adjust the slugs of L101 and L114 for maximum output. Next, adjust the slugs of L102 and L115, L103 and L116, L104 and L117, L105 and L118 on respective settings of the band switch, using the method described above.

### **RECEIVER RF AMPLIFIER:**

Set the receiver to 28.75Mc., in the AM mode, and connect a signal generator to the antenna connector. Set the generator for operation on 28.75Mc, unmodulated output. Adjust the attenuator on the signal generator to read S6 on the S-meter. Set the preselector control knob to center scale. Adjust L107 for maximum S-meter reading. Next, adjust the slugs of L108 through L111 respectively on appropriate settings of the band switch. In each case, employ the method just described to effect the adjustment. Finally, set the transceiver to transmit mode and adjust the controls for maximum output. Release the microphone push button and ascertain that the maximum receiver noise occurs at the same setting of the preselector control, i. e., center scale. If this is not the case, adjust the slugs very slightly for each of the appropriate bands until the two settings are nearly the same.

# VOLTAGE CHART

		Emitter	Base	Collector
TR101	RF Amp.	4.6V	4.V	0.3V
102	Heterodyne OSC.	0.6	0.6	8.2
103	" REC.	12	11.5	0.2
104	" TRANS.	10	9.5	0.4
TR201	IF Amp.	11.8	11.1	0.4
202	"	11.5	11.1	0
203	"	11.6	11.1	0
204	AGC Amp.	0	0.2	0.1
205	S-meter	0.1	0.1	12.5
206	Carrier OSC USB	1.7	0.4	8.2
207	" LSB	3.1	0.1	8.2
208	REC Audio Amp.	9.9	8.7	2.4
TR301	100 KC Calibrator	1.1	0.2	12.1
302	REC VFO Mixer	11.5	11.	0.2
303	TRANS VFO Mixer	10.5	9.9	0.2
304	REC Audio Driver	9.4	7.5	0.5
305	REC output	12.7	12.4	0
306	" "	12.7	12.4	0
307	MIC Amp.	6	4.3	1.8
308	" "	7.2	4.2	1.8
TR401	VFO OSC.	1.6	2	5.9
402	VFO Buffer.	0.7	1.1	7.7
TR501	FIX CHANNEL OSC.	0.8	0.6	8.4

PIN NO.	1	2	3	4	5	6	7	8	9	10	11	12
12BY7A(REC)	0	-150V	0	12VAC	0	270V	200V	0				
(TRANS)	2.5V	0	0	12VAC	0			0			PLATE	
6JM6 (REC)	12VAC		165V		-150V				0		540	
(TRANS)	12VAC		150V	0	-30V				0		500	

## EXT AMP CONNECTION

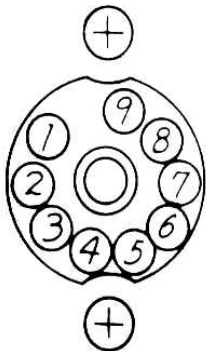

1. GROUND.
2. +12V DC.
3. P.T.T. TERMINAL
4. N.C FOR TRANSMIT.
5. CLOSE AT TRANSMIT.
6. RELAY COMMON.
7. CLOSE AT RECEIVE.
8. N.C
9. N.C

# PARTS LIST FTDX-100

C-CAPACITOR		609	0.001 TV3K MICA
101, 113, 308	50 P 500W V ±10% F.M.	610	0.005 TV3K MICA
102, 103, 104, 114, 115, 116 124-126	70 P 500W V ±10% F.M.	624	680 P 500W V ±10% F.M.
105, 117, 131, 144	200 P 500W V ±10% F.M.	618, 620	1000 P 500W V ±10% F.M.
106, 112, 128, 129, 132, 136 140, 205, 208, 214, 217, 221 224, 227, 229, 309, 402, 404 501, 503	100 P 500W V ±10% F.M.	701, 702	0.01 μ 1.4KV A.L. DISC
107, 122, 128	150 P 500W V ±10% F.M.	703, 704	20 μ 300W V ELECTROLYTIC
108, 111, 202, 303, 330, 406	470 P 500W V ±10% F.M.	705	40 μ 300W V ELECTROLYTIC
109, 110, 130, 135, 235, 236 219-221, 230, 325-327 401, 403, 407, 408, 413, 502, 504, 505, 622 801-807, 809	0.01 μ 50W V DISC	706 709	0.005 1.4KV A.L. DISC
118-121, 601-604, 606 608, 612, 613, 810-812	0.01 μ 500W V DISC	R-RESISTOR	
123, 134, 145, 218, 203 204	10 P 500W V ±10% F.M.	102, 103, 202, 238, 206 213, 218, 242, 327, 610 614	470 Ω ½W 1 K ½W
133, 213	30 P 500W V ±10% F.M.	104, 120, 205, 209, 210 241, 307, 308, 317, 319 322, 405, 408, 615, 705 753, 801, 907, 908	2.2 K ½W
137, 141, 207, 209-212 215, 216, 222, 223, 225 226, 228, 305, 306, 306 312, 313, 908, 909, 913	0.05 μ 50W V DISC	105, 233, 237, 239, 240 318, 407, 914	47 K ½W
138, 139, 304, 310, 311	0.001 μ 50W V DISC	106, 328, 329, 331, 704 706, 802, 910	56 ½W
142, 143, 146, 147, 307, 409	40 P 500W V ±10% F.M.	107, 601, 605	100 Ω ½W
232, 234, 315, 316, 324 903, 905, 906	100 μ 15W V ELECTROLYTIC	108, 217, 245, 315 109	33K 2W 10K 1W
230, 231, 314, 320, 331 332, 619, 901, 904, 907	1 μ 15W V ELECTROLYTIC	110 111	4.7K 1W
233	200 μ 10W V ELECTROLYTIC	113, 214, 215, 223, 224 227, 228, 402, 502	220 Ω ½W
301, 302	2000 μ 25W V ELECTROLYTIC	115, 122, 221, 403, 504 913	22 K ½W
317	0.2 μ 50W V MYLAR	116, 216, 222, 230, 404 806, 906	4.7 K ½W
318	0.5 μ 50W V MYLAR	117, 401	22 Ω ½W
319, 609, 621, 623, 902 910, 912	10 μ 15W V ELECTROLYTIC	118, 204, 208, 211, 220 226, 229, 305, 309, 330 609	33 K ½W
321, 321, 911	30 μ 15W V ELECTROLYTIC	119, 123, 203, 207, 210 306, 310, 312, 314, 503 708, 805	3.3 K ½W
328, 329	40 μ + 40 μ 450W V	121, 241, 243, 246, 915	330 ½W
304	0.002 50W V DISC	124, 201, 236, 304, 320 323, 410, 505, 604, 606 612, 707, 803, 903, 909	10 K ½W
405	250 P 500W V ±10% F.M.	231, 232	150 Ω ½W
410	12 P U J CERAMIC	234	270 K ½W
411	20 P 500W V ±10% F.M.	311, 321, 906	15 K ½W
412	5 P 500W V ±10% F.M.	302, 313	180 Ω ½W
605	0.047 600W V M.P.	324, 333, 701, 702, 804 303, 325, 326, 334 613, 902, 912, 916	470 K ½W 100 K ½W
		406	1.5 K ½W
		501	10 Ω ½W
		602, 603, 711	56 Ω 1 W
		611	680 Ω ½W
		703	5.6 Ω 4 W

750	47.0	6 W		VR-POTENTION METER
751	22.0	1 W	201	B. M. 200 Ω B
752	10.0	1 W	202	REG 500 Ω B
901, 905	220 K	1/2 W	301	S-M 1 K B
911	1 M	1/2 W	302, 303	10 K B
TR-TRANSISTOR			304	20 K B
101	2 S A	2 3 9	701	BIAS 20 K B
701, 702	B-1	1 3 0 0	801	RFA 50 K B
103, 104	2 S A	2 4 6	802, 2	RF/AF 1 KB-10KB DOUBLE
201-203, 302, 303	2 S A	4 6 9 6 9 3	803, 3	MIC/AM 10KB-10KB DOUBLE
204, 205	2 S D	1 9 1	804	VOX 10 K B
209	2 S C	5 0 4	805	ANTI TRIP 10 K B
304, 307, 905	2 S B	9 4	TC-TRIMMER	
305, 306	2 S B	2 0 0	101 111, 302	20 P CERAMIC
208, 308, 601, 901, 902	2 S B	5 4	201 203	50 P CERAMIC
102, 207, 208, 210, 401	2 S C	3 7 2	301	100 P PACKING
402, 501			401	30 P KC-30 AIR
903, 904	2 S C	3 7 3	601	10 P KD-10 AIR
301	2 S C	3 6 7	TH-THERMISTOR	
D-DIODE			301	D 6 1 A
101, 102, 105-107	1 S 1 0 0 7	GEL.	RL-RELAY	
201-211, 302 305			301, 302	AW744819 DC12V
602, 801			601	SRE 2D12DC12V
103	1 S 3 3 1	6V ZENER	PL-PILOT LAMP	
212	1 S 3 3 4	9V ZENER	401, 402	15V LAMP
213	1 S 9 9 3	3V ZENER	J-JACK	
401, 501	1 S 1 4 5	VARI. CAP	801	AUX SB-1221
601, 603, 705, 706	S H 1	SILICON	802	MIC SG-4601
901 903			803	PIN S-Q, 2301
701 704	S D 1 C	SILICON	804	SP S-I-7510
707 711	S D 1 Y	SILICON	805	POWER 450-AB12M
X-CRYSTAL			806	KEY S G 3207
101	80 m	9.22MC HC 18 U	807	COAX JSO-239
102	40 m	12.72MC HC 18 U	P-PLUG	
103	20 m	19.72MC HC 18 U	801	AUX SI-8501
104	15 m	26.72MC HC 18 U	802	MIC SH 3601
105	10 A	33.72MC HC 18 U	803	PIN S Q 2702
106	10 B	34.22MC HC 18 U	804	SP S I 7509
107	10 C	34.72MC HC 18 U	805	POWER 450-P12F
108	10 D	35.22MC HC 18 U	806	KEY SH-3001
207	USB	3178.4KC HC 6 U	807	COAX MP-7
208	LSB	3181.6KC HC 6 U	T-TRANSFORMER	
201	X F	3180.9KC HC 6 U	302	INPUT ST-29
202	"	3180.9KC HC 6 U	303	OUTPUT ST-41
203	"	3179.1KC HC 6 U	701	POWER
204	"	3179.1KC HC 6 U	702	BASE OSC
205	"	3178.4KC HC 6 U	CH-FILTER CHOKE	
206	"	3181.8KC HC 6 U	801	100 m H 0.5 A
301	CAL	100KC HC 13 U	M-METER	
VC-VARIABLE CAPACITOR			801	MRA45 250/1mA
101	(330 P + 25 P) × 3	B 5 3 5	F-FUSE	
401	20 P × 3	B 5 1 5	801	3 A SM 0108
601	240 P	Y C 2 4 0	K-KNOB	
602	430 P × 2	B 7 2 4 0	1 3	FT 25 T
S-SWITCH SWITCH			4 9	FT 25
101	BAND	RS 8 12 11	10	DIAL
801	SELECT	RS 2 4 6		
802	MODE	RS 2 6 4		
803	POWER	WD 3 0 0 1		
804-806		MSL 2 0 3 N		
807	STANBY	WD 3 1 2 1		
808	VOX/PTT	MS 1 0 1 2		



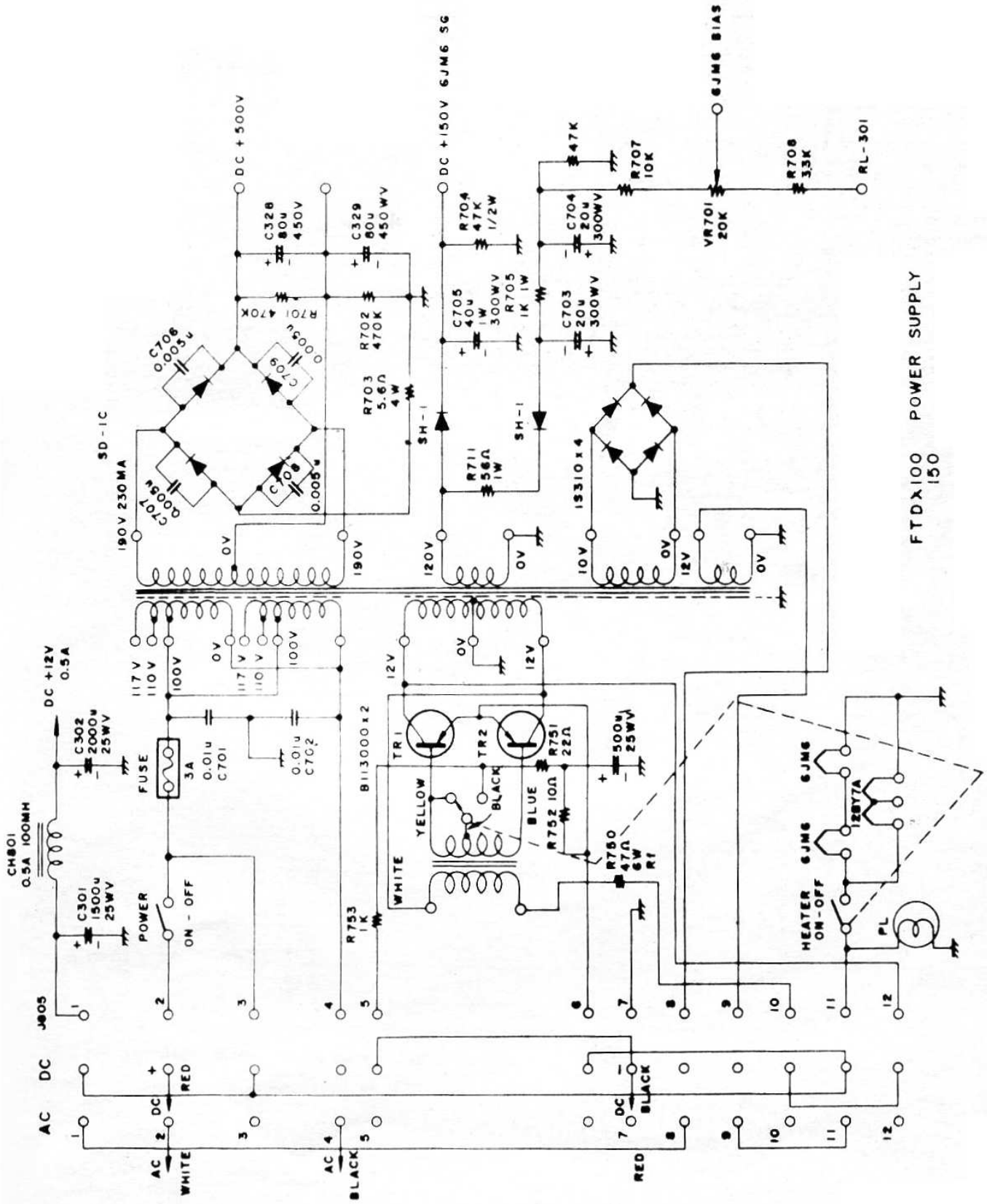

FTDX100 POWER SUPPLY  
150

# BLOCK DIAGRAM FOR FT-100B

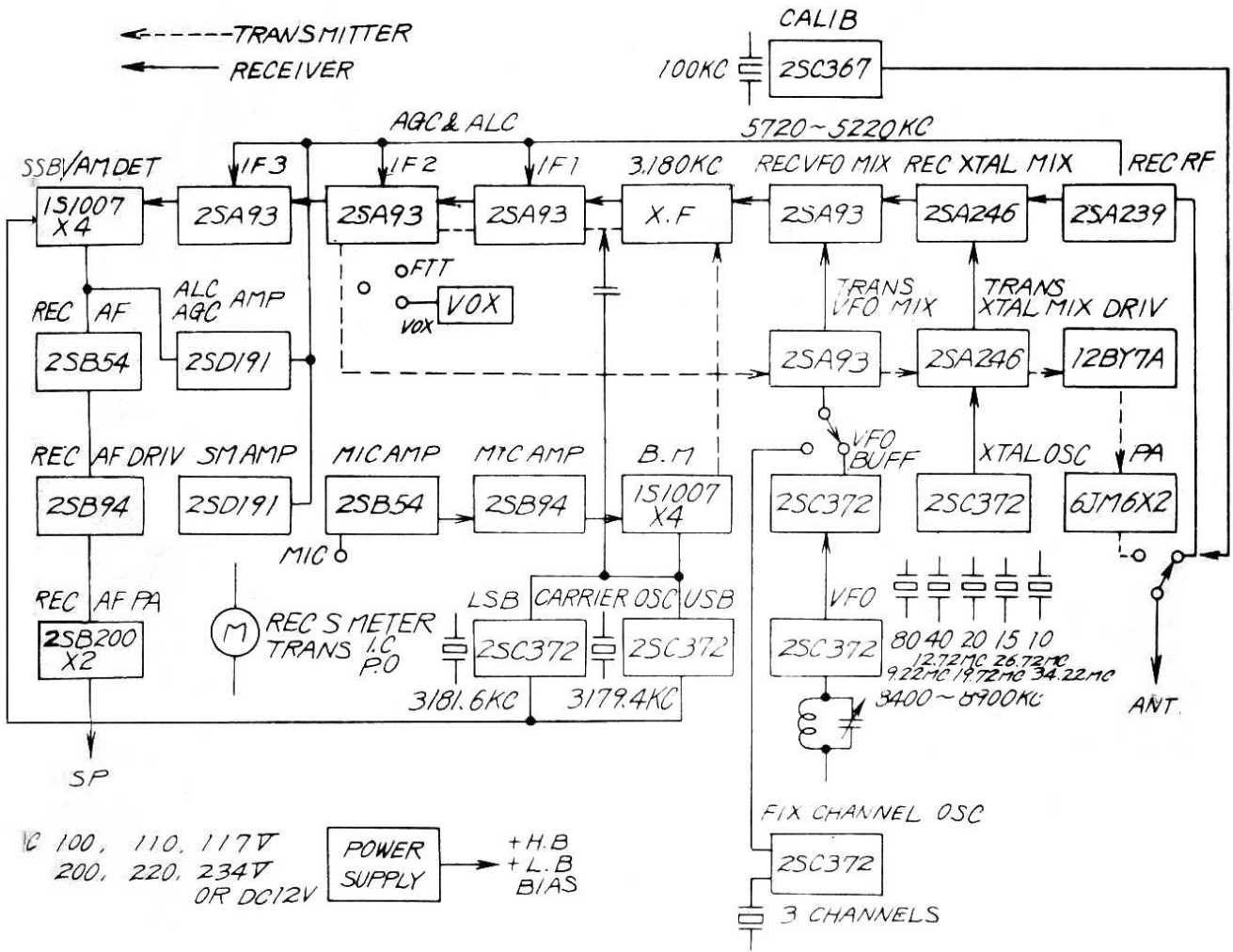

## PLUG CONNECTIONS

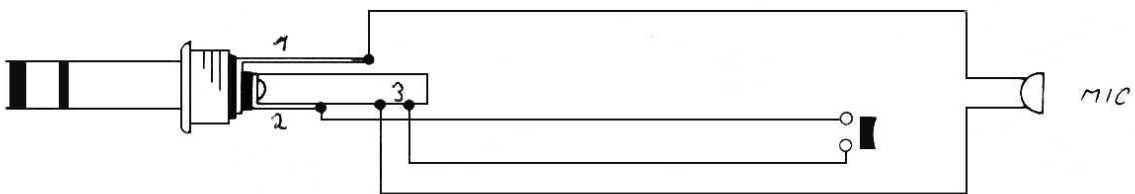

Ground Lead for microphone should be to ired separately and connected together to the ground lead of PTT switch

